

Square Root Transmitter ST20

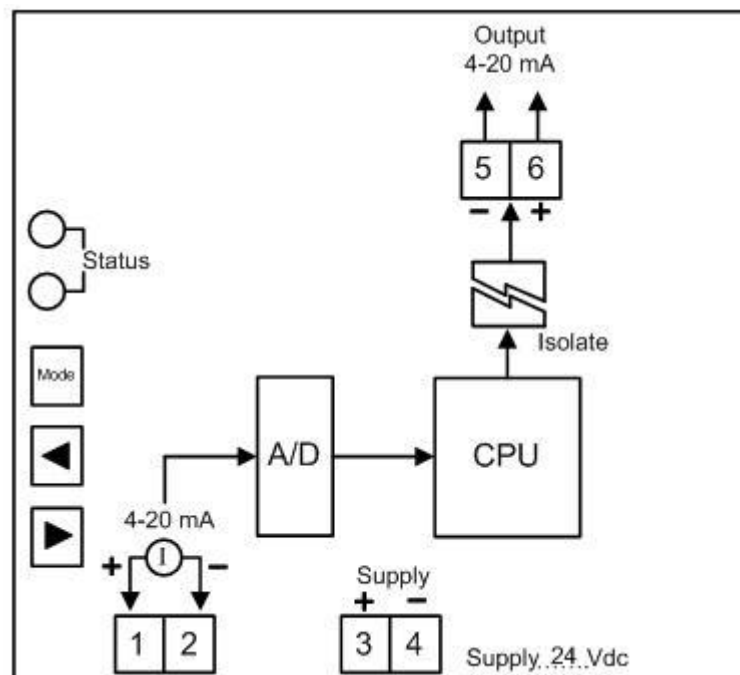

- Squared Input
- High precision performance
- High accuracy

The Square Root Transmitter ST20 is square root computer. It is designed to solve the equation $Q = C \sqrt{\Delta P}$ where ΔP is the differential pressure across an orifice, and C is a constant relating the orifice plate to engineering units. Because ST 20 does not use the curve segment, biased diode technique, it provides accuracy and resolution limited only by the stability and calibration of the orifice plate and its transmitter. The ST 20 output is a standard process current or voltage signal that is linearly proportional to flow.



Specifications

Analog Input

Number of channel: 1 Channel

Input type: Current, Voltage

Input range:

Current (0-20, 4-20 mA)

Voltage (0-5, 1-5, 0-10 VDC)

Input - Output Equation = %Output =
 $\sqrt{100 \times \%Input}$

Output

Number of channel: 1 Channel

Output type: Current, Voltage

Output range:

Current (0 to 20, 4 to 20 mA)

Voltage (0 to 5, 1 to 5, 0 to 10 VDC)

Linearity: $\pm 0.5\%$ of span

Span: Adjustable $\pm 10\%$ of full scale output

Zero: Adjustable $\pm 5\%$ of full scale output

Power Requirements

Power Supply: 24 VDC

Environmental Limits

Operating Temperature: 0 to 55 °C

Operating Humidity: 5 to 95% RH

Storage Temperature: 0 to 70 °C

Physical Characteristics

Dimension: W20 x H100 x D118 mm.

Mounting: DIN Rail

Warranty

Warranty Period: 5 year

Ordering Information: Specify Input, Output

Example ST20/4-20 mA/4-20mA

Package Checklist

1. ST20
2. Manual

